

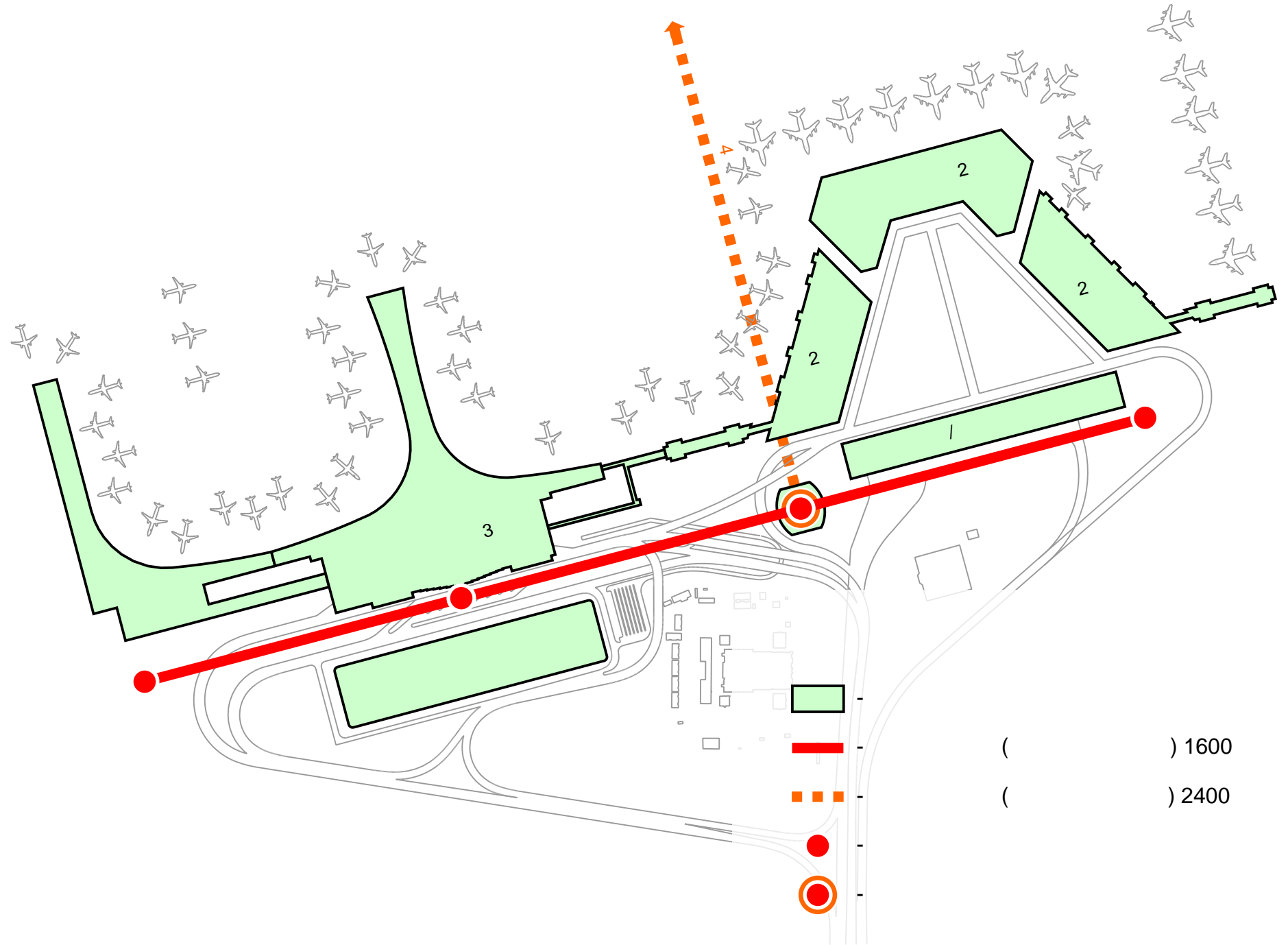

2009



	ì	1600	1600(2)	1600	1600(2)
		1,25	1,25	1,25	1,25
		30–60	30–60	200–500	200–500
		5–15	5–15	10–25	10–25
	.	48	48	48	48
(1000 ./)	.	2	2	2	2
	/	60	60	60	60
()	.	3,1	3,1	3,1	3,1
	.	4	4	4	4
	./	2000	15000	2000	15000
	.	70	130	50	90
	.	50	50	50	50
	.	60	125	60	125
-	.	40	40	40	40
	.	35	60	35	60
	.	255	405	235	365





①

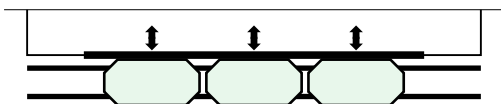

②

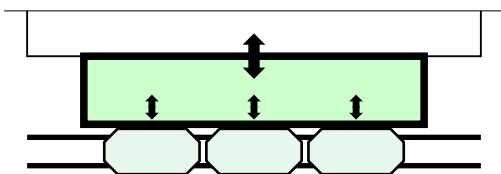

③

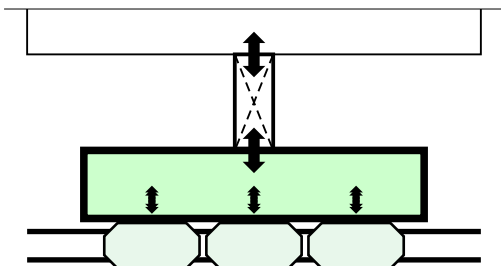

①

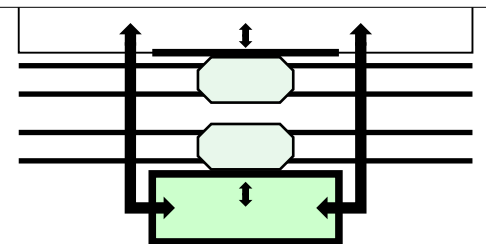

②

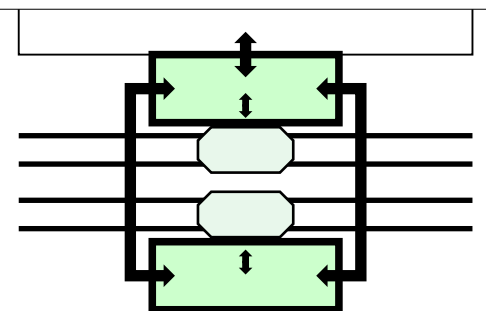

③

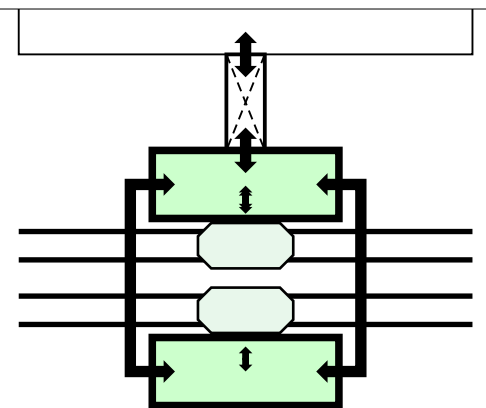

①

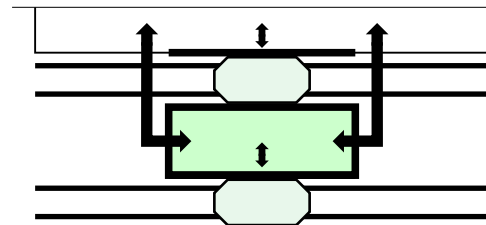

②

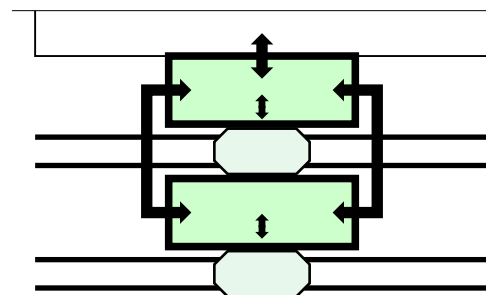

③

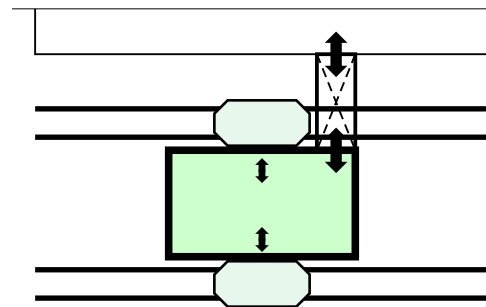

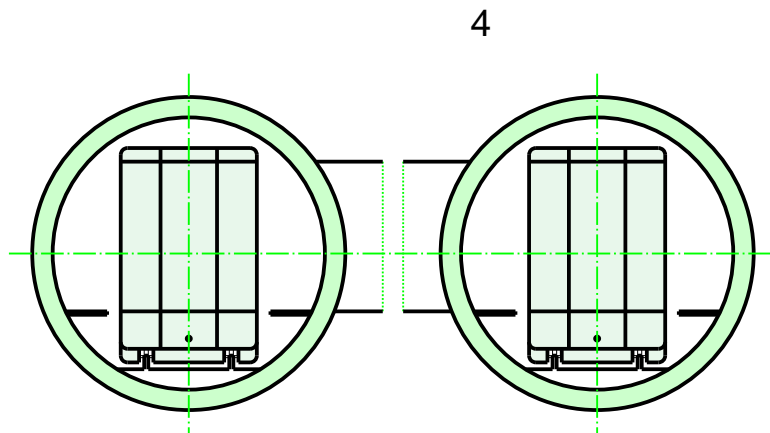

6

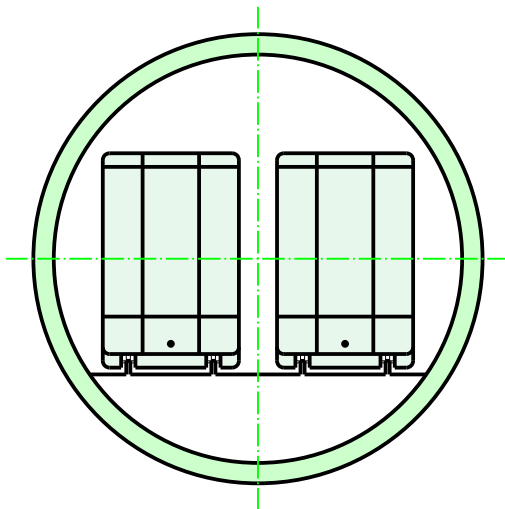

	.	
	ì	2400
		1,25
		10
		0,1
	.	48
(1000 ./)	.	3
	/	80
()	.	2,5
	.	2
	./	15000
()		
	. .	90
	. .	75
	. .	105
-	. .	40
	. .	45
	. .	355